

HUBER

Screenings Wash Press WAP[®] SL



Super Launder Wash Press for disposal cost reduction

- Weight reduction of up to 85 %
- Compaction of up to 50 % DS
- High washed screenings quality of < 20 mg BOD₅ / g DR
- Disposal cost reduction by up to 10 % compared to conventional wash press systems

►► Function

The WAP® SL operates in a batch mode. Screenings either drop into the launder tank directly from a screen or conveyor, or they are flushed into the tank through a launder channel. After a batch of screenings has been fed, the tank is filled up with wash water and agitated for an adjustable period by means of an impeller. The fecal matter is loosened and removed from the screenings by high turbulence and shear.

After the washing cycle has been finished, an automatic valve opens and the wash water drains through perforations in the trough. It returns, together with the fecal matter, to the wastewater flow. A screw in the trough conveys the screenings towards the mouth of a tube whereby they are, as an additional option, rinsed with spray water. The screw pushes the screenings through the pressure zone where they are compressed, dewatered and compacted before they are finally discharged through the discharge pipe into a dumpster or bagger.

►► Feeding options

Feeding through a launder channel

The screenings drop from the screen or conveyor into a HUBER Launder Channel HCL. Screened wastewater or process water flushes the screenings through the channel into the launder tank of the washpress. The flush water also serves as wash water in the launder tank.

Feeding directly from a screen or conveyor

The screenings drop from the screen or conveyor into the launder tank. Screened wastewater or process water is directly introduced into the tank as wash water.



High turbulence in the launder tank during impeller operation

►► Benefits

- Very clean screenings due to volume, weight and disposal cost reduction of up to 85%
- High-intensity washing in launder tank
- Washed screenings quality < 20 mg BOD₅ / g DS
- Compaction up to 50 % DS
- Screenings processing capacity of up to 12 m³/h (420 ft³/hr)
- Screened wastewater or process water can be used as wash water
- Sturdy, durable design
- All structural parts, including the screw, are made of stainless steel to prevent corrosion
- Fast payback due to great transportation and disposal cost savings
- Disposal cost reduction by up to 10 % compared to conventional wash press systems

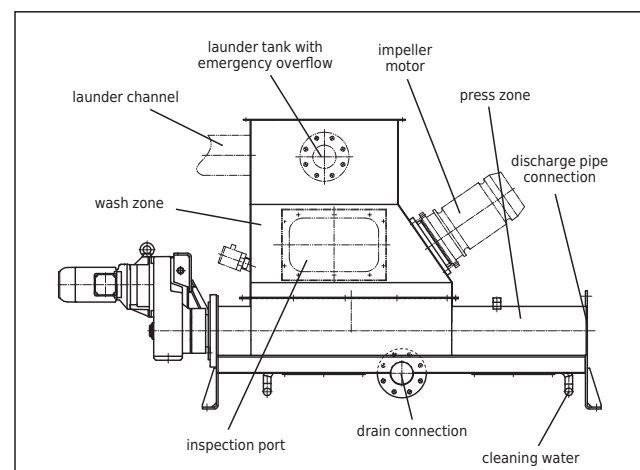

Well washed and virtually odorless screenings from a HUBER Screenings Wash Press WAP® SL, compacted to 50 % DS

HUBER SE

Industriepark Erasbach A1 · D-92334 Berching
Phone: + 49 - 84 62 - 201 - 0 · Fax: + 49 - 84 62 - 201 - 810
info@huber.de · Internet: www.huber.de

Subject to technical modification
0,1 / 8 - 1.2021 - 10.2003

HUBER
Screenings Wash Press WAP® SL