

[Home](#) ■ [HUBER Report](#) ■ [Sludge Treatment](#) ■

[New HUBER Screw Press Q-PRESS® 620.2 for sludge dewatering: operational experience](#)

[New HUBER Screw Press Q-PRESS® 620.2 for sludge dewatering: operational experience on STP Bad Orb](#)



*HUBER Screw Press Q-PRESS® 620.2 with open cover*



*Stationary unit of a HUBER Screw Press Q-PRESS® 620.2*



*Partial section of a HUBER Screw Press Q-PRESS®*

The further developed HUBER Q-PRESS® was presented for the first time at IFAT 2016. The first units were installed soon and have meanwhile been in operation for more than a year. Now, it is time to review the operational experience gained on site against development targets.

In April 2016, a new sludge dewatering system for STP Bad Orb was put out to tender to replace a chamber filter press. Extensive on-site testing was done before in 2015. During the tests, the screw presses turned out to be the most suitable dewatering solution.

HUBER offered the newly developed HUBER Screw Press® 620.2 and could win the tender which included a screw press, the electrical control system, conveying technology, coagulant agent plant for simultaneous conditioning of liquid and powdery polymer, and a solution for bridging the time of installation.

The screw press was installed and successfully put into operation in October 2016. The operating staff on site had already time to get familiar with the operation of the machine during the installation phase when a mobile Q-PRESS® 440 unit was operated on site as a transitional solution.

### Performance data of the HUBER Screw Press Q-PRESS® 620.2

Throughput:	5 – 7 m³/h
	100 – 210 kgDR/h
Polymer demand:	15 kg/t; 1:1 mix of powder/liquid
Dewatering results:	24 – 27 % DR
Separation degree:	> 97 %
Screw rotation speed:	0.3 - 0.4 rpm
Power consumption:	0.5 – 0.8 kW

The Q-PRESS® on STP Bad Orb has already dewatered approximately 7000 m³ sludge since when it was put into service. We would like to thank the operators for their cooperation and excellent support when we were testing new drive technologies on the screw press.

In addition to the installation in Bad Orb, another eight HUBER Screw Press Q-PRESS® 620.2 units have been installed successfully.

## HUBER Screw Press Q-PRESS® – features of the new model

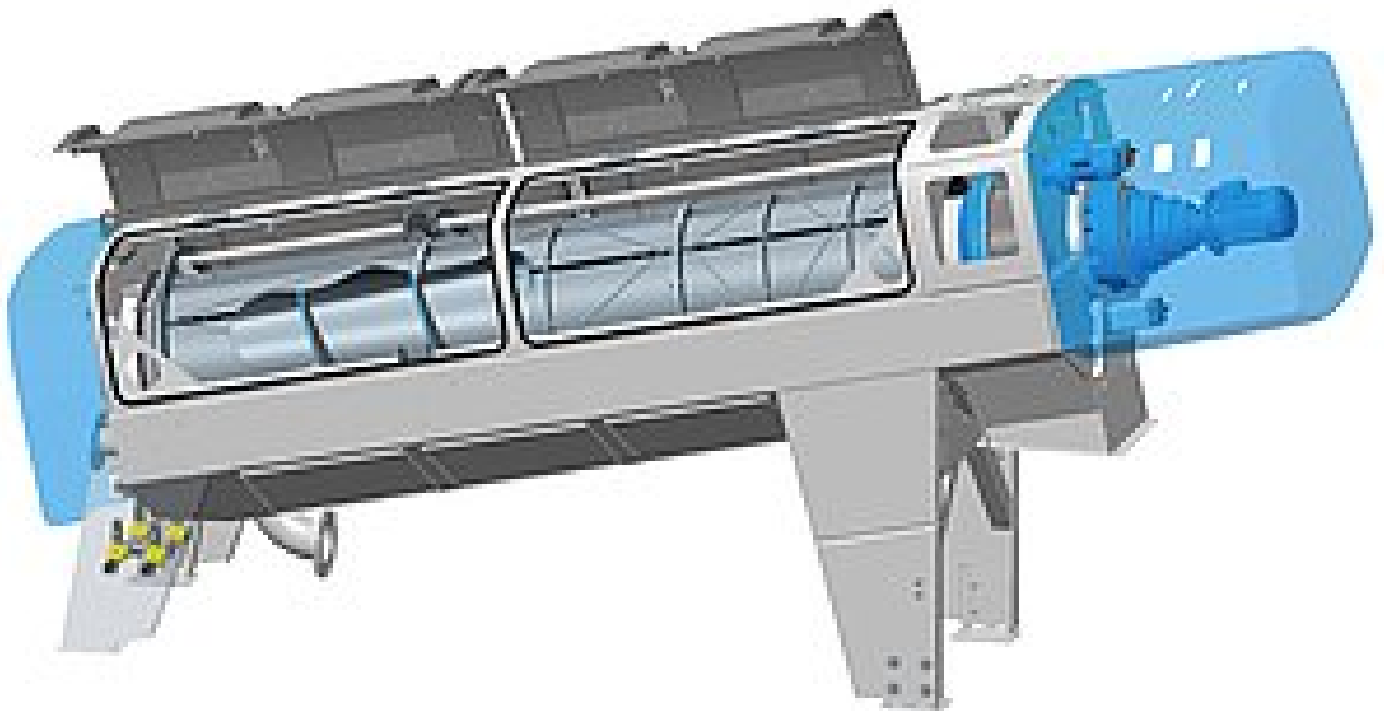

### Easier maintenance and reduced space demand

Axially dividable filter baskets are optionally available, they facilitate maintenance work significantly. Massive components, such as the screw shaft and some filter elements, can now remain in the machine during inspections. Much less space and time is therefore required for maintenance. Even if non-dividable filter baskets are used, space requirements for maintenance on the installation place are now reduced to the minimum that is necessary for machine operation and inspection.

### Efficient screen surface cleaning inside and outside for improved screening performance

The outer surface of the cylindrical filter baskets was previously cleaned by rotating the filter baskets along a stationary nozzle bar while the dewatering process was interrupted. The new screw press offers continuous dewatering without interruptions through a rotating washing system that rotates around the filter baskets for periodic cleaning. Dewatering degree and machine throughput are no longer influenced by interruptions or starts/stops of the washing systems. In contrast to many competitive machines the rotating washing system allows for independent cleaning of the filter surfaces of the inlet and press zone. In addition, the upper and lower filter halves can be cleaned separately so that only the contaminated filter surface sections are cleaned. Filter surface sections which have been cleaned cannot be contaminated again by wash water that runs down. This system significantly reduces the water demand for filter

cleaning and additionally minimizes rewetting of the sludge cake through washing.

Reliable cleaning of the inner screen basket surfaces is just as important as cleaning of the outer surfaces. The inner surfaces are typically cleaned by a scraper that is mounted on the screw flights and wipes clear the inner filter surface as the screw shaft rotates. The efficiency of this scraping & wiping operation has direct influence on filter resistance and the water discharge velocity of the screw press. Both have an influence on dewatering degree, throughput, filtrate quality, polymer demand, and thus on the operating costs for dewatering. After extensive development and test series HUBER screw presses are now equipped with an innovative, especially designed patented scraper material which cleans the inner filter surface much better and more reliably than customary brushes and a lip seal system.

### Larger screening surface for increased hydraulic throughputs

What is new is that the open filter surfaces in the filter baskets have been increased by up to 100%. The individual screen sizes are therefore able to process significantly higher hydraulic loads without placing higher loads on the filter surfaces and thus the filtrate, and without increasing polymer demand.

### More efficient drives for improved performance with reduced energy costs

New drives exceed current energy efficiency standards. They save not only electricity costs, they also offer plant operators the possibility to operate their sludge dewatering unit much more flexibly due to significantly wider motor speed ranges.

### Inclined installation for improved dewatering efficiency

For good reasons, the basic appearance of the press, the inclined installation, remains as it has always been. The inclined design ensures that screenings removal units can in most cases be connected without the need to place it on an additional elevation. Furthermore, the inclination of the filtrate chambers prevents sedimentation and eliminates the need for manual cleaning work. The decisive advantage of the inclined installation is improved dewatering efficiency. The separated filtrate flows off from the screen basket by gravity, against the flow direction of the press sludge. Rewetting of hydrophilic sludges through filtrate is thus reduced and the dewatering degree improved. Moreover, inclined installation facilitates especially the start-up procedure of the screw press.

---

**HUBER CS spol. s r.o.**  
Sídlo společnosti  
Cihlářská 19  
602 00 Brno  
Česká Republika

Tel.: 532 191 545  
Fax: 532 191 575

Email: [info@hubercs.cz](mailto:info@hubercs.cz)  
Internet: [www.hubercs.cz](http://www.hubercs.cz)

Member of the HUBER group:  
[www.huber.de](http://www.huber.de)